

4640 Series

Part#	Part Height	Thread Size and Depth	Thd Depth in dec	Insert Length	# of Inserts
GINS-4640-15	6.005"	3/8-16x11/16 deep	.669"	.787"	2 top 4 bottom
GINS-4640-81	6.005"	3/8-16x11/16 deep	.669"	.787"	4 top 4 bottom
GINS-4640-M15	152.5 mm	M10-1.5 x 17 deep		20 mm	2 top 4 bottom
GINS-4640-M81	152.5 mm	M10-1.5 x 17 deep		20 mm	4 top 4 bottom

Inserts	
Part#	Material
As shown	Aluminum
Followed by -B	Brass
Followed by -S	Steel

Hex shaped Inserts

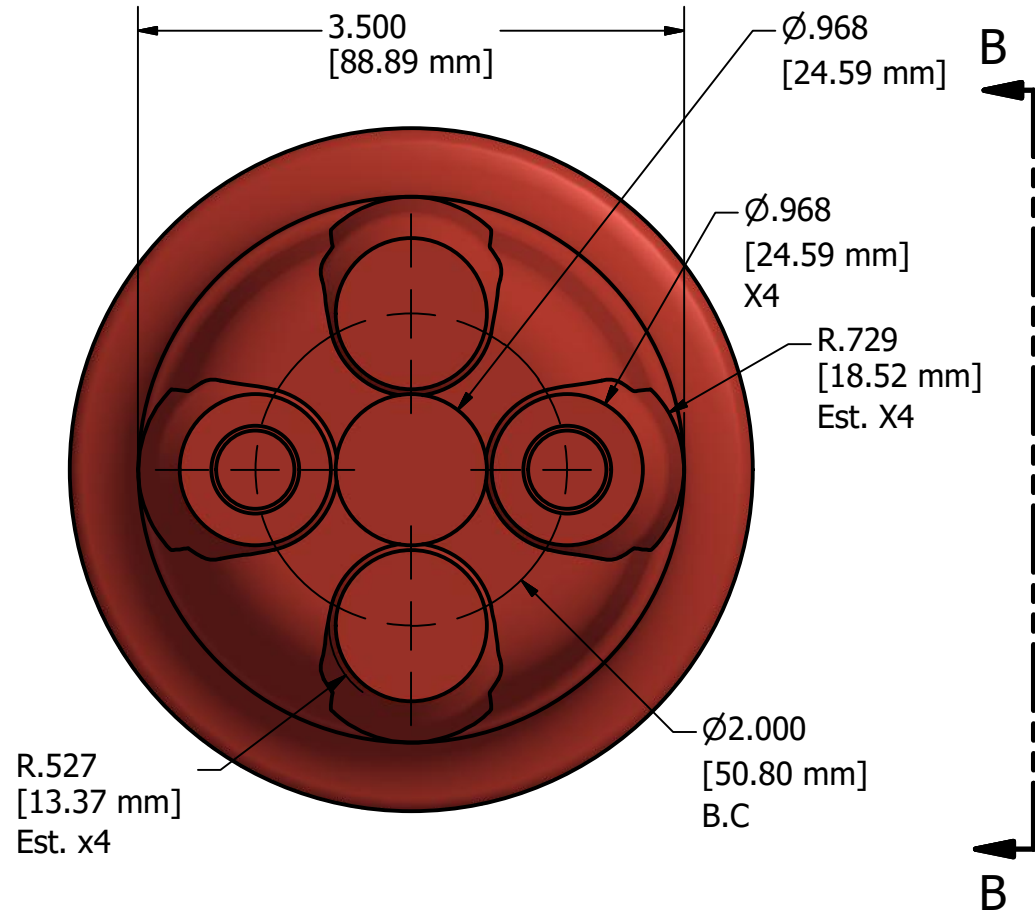
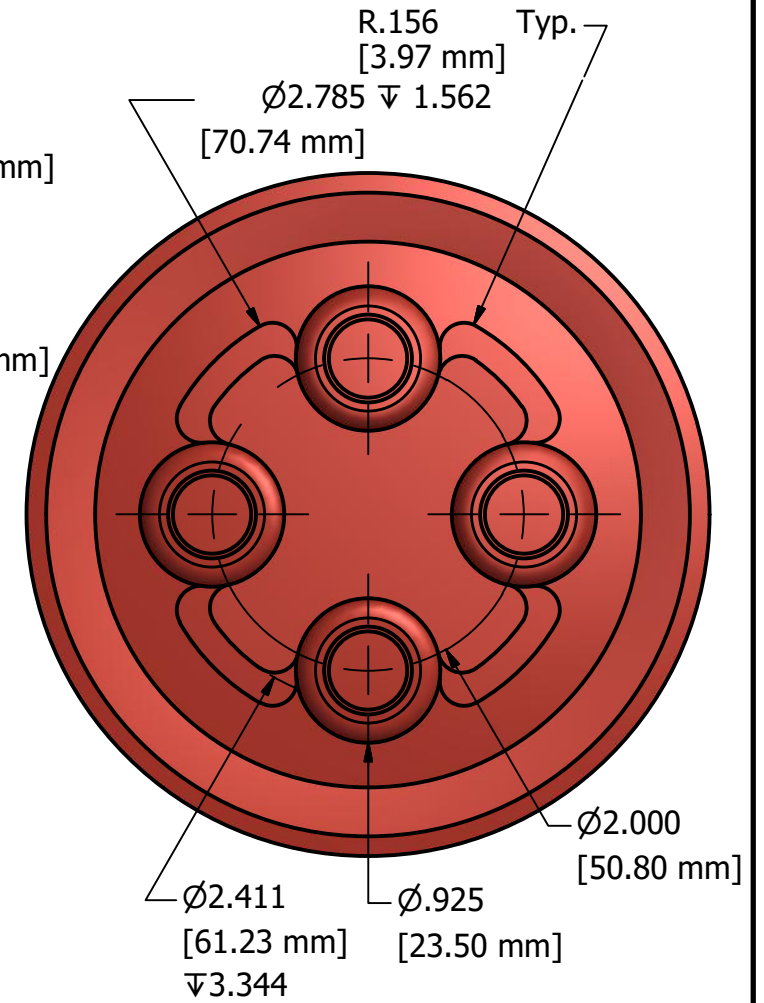
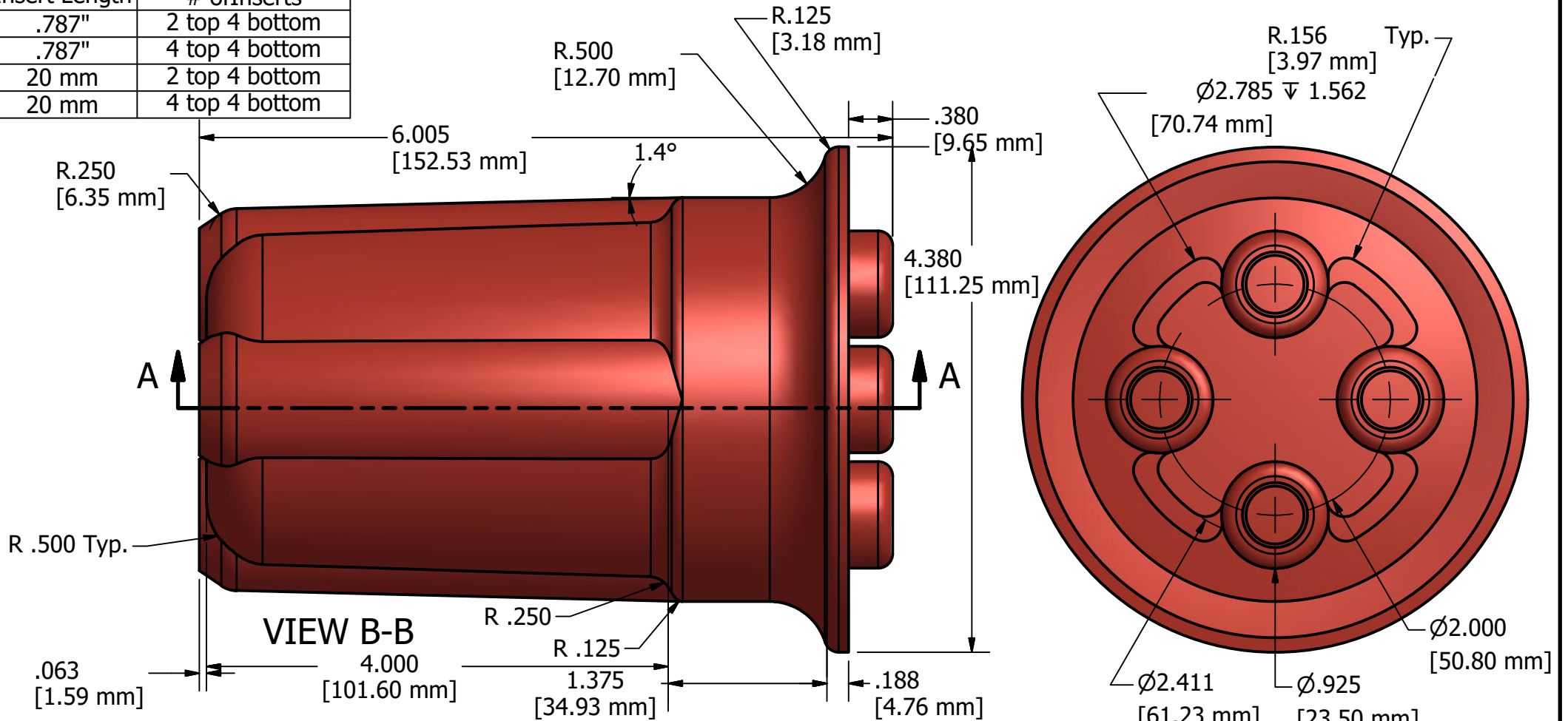
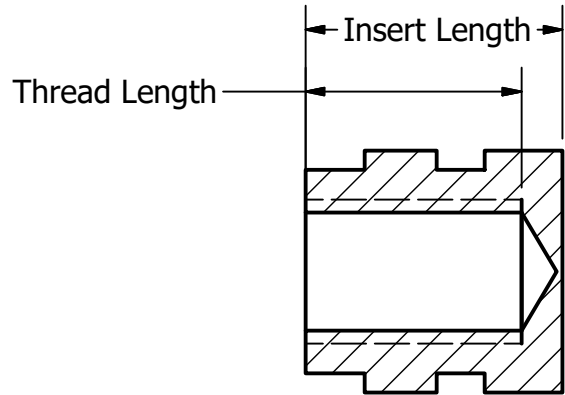

B

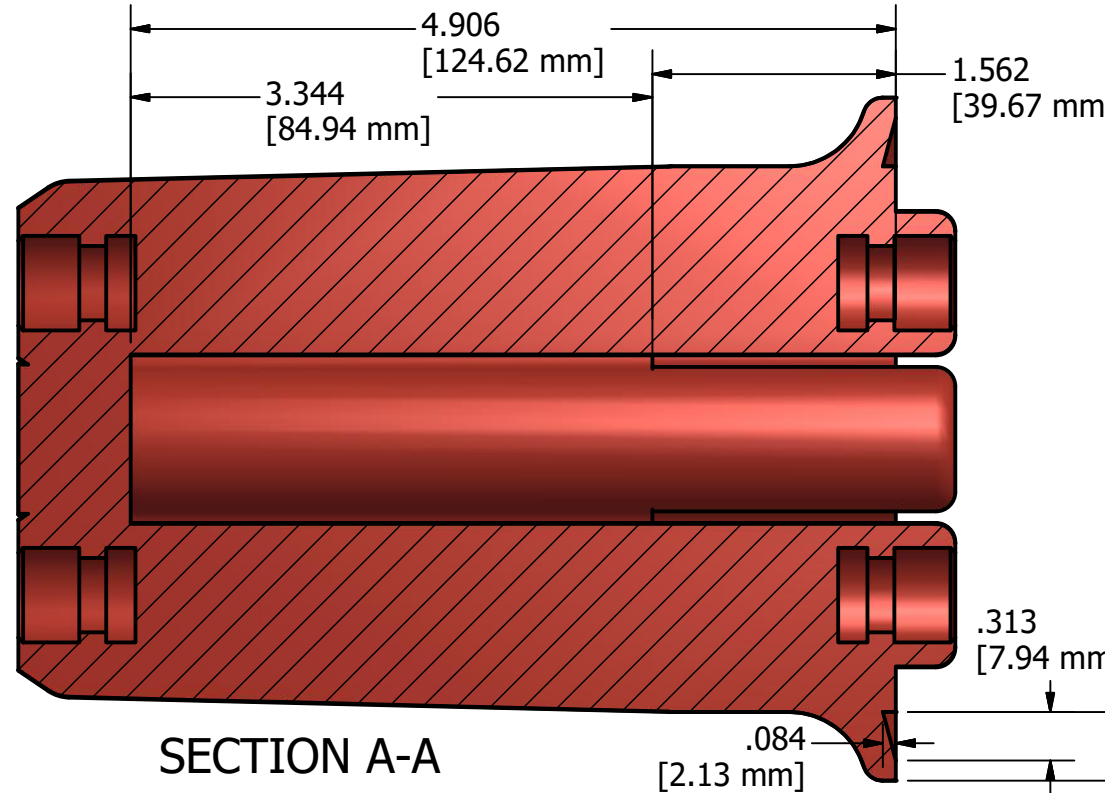

SECTION A-A  
SCALE .8125

Notes:	APPROVED BY <i>Solomon Chiang</i>	PART NAME GINS-4640 Stand Off Series
	DRAWN BY Corey Smith	CUSTOMER CONTACT
	DRAWING DATE 3/3/15 Rev 0	FACILITY

MATERIAL Aluminum insert, approved UL Glass Polyester BMC (File #354884)	QTY
TOLERANCES .xx ± .xxx ± Fract: ± Angle: ± Other: ±	 THE GUND COMPANY EST 1951 2121 WALTON ROAD ST LOUIS MO 63114 USA (314)-423-5200 FAX (314)-423-9009
Drawing Reference	